



General Certificate of Secondary Education
2024

Centre Number

--	--	--	--	--

Candidate Number

--	--	--	--	--

Physics

Unit 1

Higher Tier



[GPY12]

GPY12

FRIDAY 7 JUNE, AFTERNOON

TIME

1 hour 30 minutes.

INSTRUCTIONS TO CANDIDATES

Write your Centre Number and Candidate Number in the spaces provided at the top of this page.

You must answer the questions in the spaces provided.

Do not write outside the boxed area on each page or on blank pages.

Complete in black ink only. **Do not write with a gel pen.**

Answer **all** questions.

INFORMATION FOR CANDIDATES

The total mark for this paper is 100.

Figures in brackets printed down the right-hand side of pages indicate the marks awarded to each question or part question.

Quality of written communication will be assessed in Question **2(d)**.

14067.06R



28GPY1201

BLANK PAGE
DO NOT WRITE ON THIS PAGE

14067.06R



28GPY1202



1 (a) A space shuttle travels 36 000 km in 2 hours.

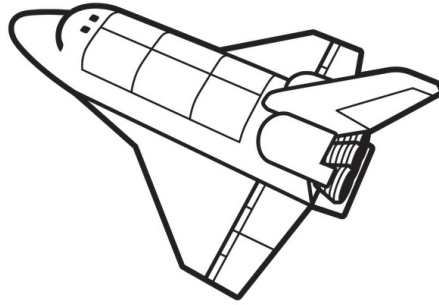

Source: © Getty Images

Calculate the average speed of the shuttle in m/s.
Show clearly how you get your answer, starting with the equation you plan to use.

Average speed = _____ m/s [4]



(b) The diagram below shows apparatus which can be used to calculate the average speed of a ball moving down a runway.

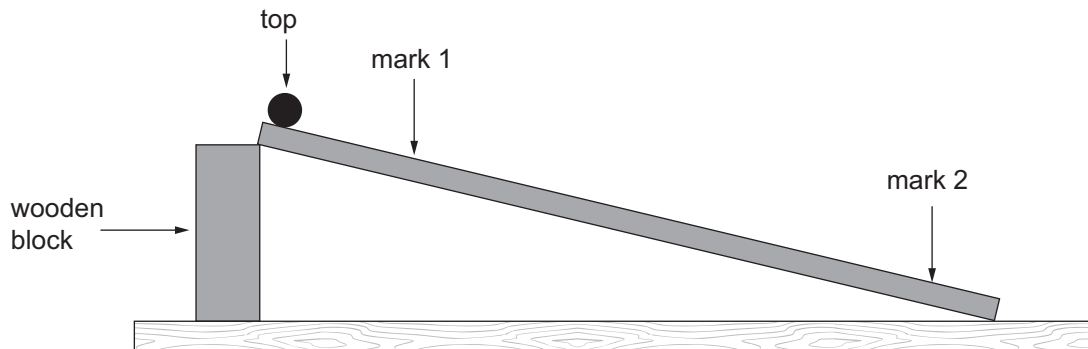

The average speed of a ball, released from rest at the top of the runway, is calculated for two journeys. Firstly, from the top to mark 1 and then from the top to mark 2.

The average speed can be calculated using the equation below.

$$\text{Average speed} = \frac{\text{final speed} + \text{initial speed}}{2}$$

How would the average speed of the ball for the longer journey compare with the average speed for the shorter journey?

Place a tick (✓) in the correct box below.

Same as.	<input type="checkbox"/>
Less than.	<input type="checkbox"/>
Greater than.	<input type="checkbox"/>

[1]

Explain your choice using the equation above.

Do not refer to distance in your answer.

[2]



- (c) The diagram below shows part of the journey taken by a person walking through a maze. Some values of distance are shown.

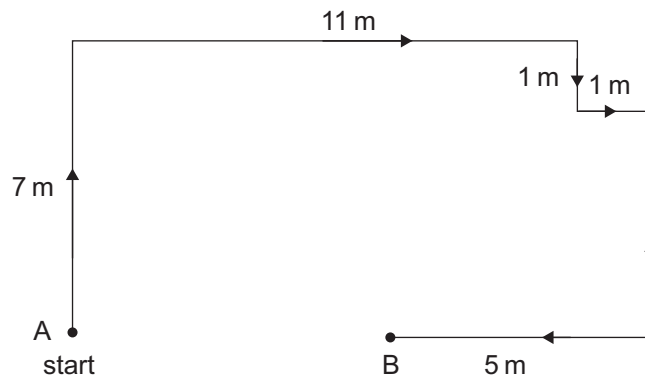

- (i) Explain the difference between distance and displacement.

[2]

- (ii) If the person starts their journey at A, calculate the total distance travelled when they arrive at B.

Distance = _____ m [1]

- (iii) Calculate the **displacement** of the person from A, when they arrive at B.

Displacement = _____ m to the _____ of A [2]

[Turn over

14067.06R



28GPY1205

(d) The displacement–time graph for a car’s motion is shown below.

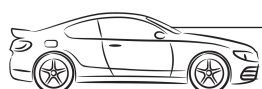

the car initially moves to the right

Source: © Getty Images

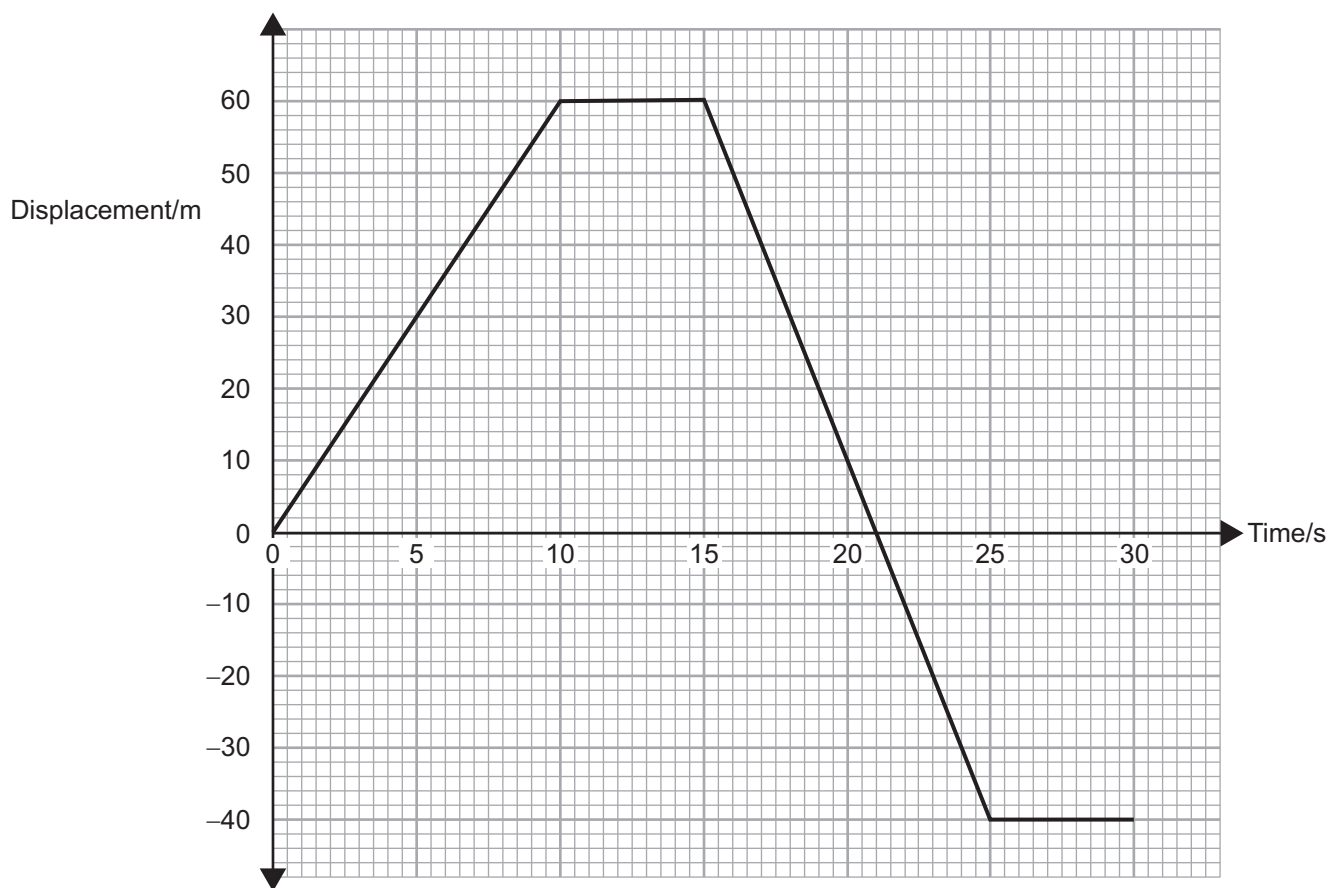

- (i) Calculate the velocity of the car for the first 10 seconds of its motion. **Show clearly how you get your answer, starting with the equation you plan to use.**

Velocity = _____ m/s [3]



- (ii) Calculate the **average speed** of the car for the 25 s of its motion.
Show clearly how you get your answer, starting with the equation you plan to use.

Average speed = _____ m/s [3]

14067.06R

[Turn over



28GPY1207

- (e) Three children are riding their bicycles on a straight track. The velocity–time graph for each child is shown below.

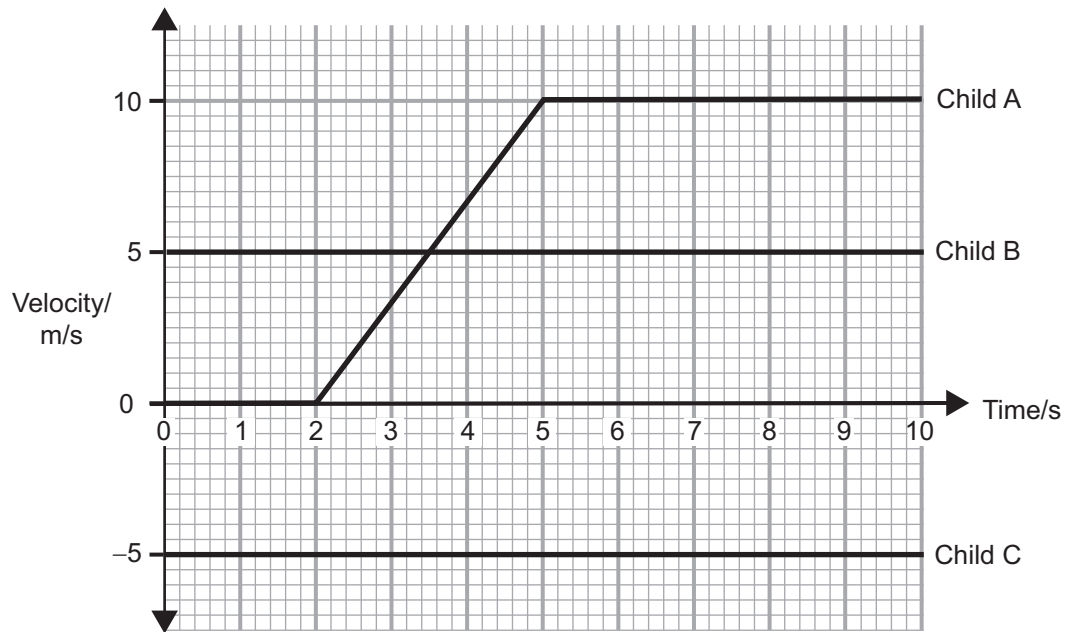

- (i) How far is child B in front of child A when child A begins to cycle?
Show clearly how you get your answer.

_____ m [2]



- (ii) Calculate the acceleration of child A between $t = 2\text{ s}$ and $t = 5\text{ s}$.
Show clearly how you get your answer, starting with the equation you plan to use.

Acceleration = _____ m/s^2 [3]

- (iii) Compare the graphs of child B and child C.
State what is the same and what is different about their motion.

Same _____

Different _____ [2]



- 2 (a) (i) Complete the following statement of Newton's second law.
Write the words in the spaces provided.

A _____ force will cause an object to accelerate and
the acceleration is _____ to the size of
this force. [2]

The diagram shows a trolley used in school science.

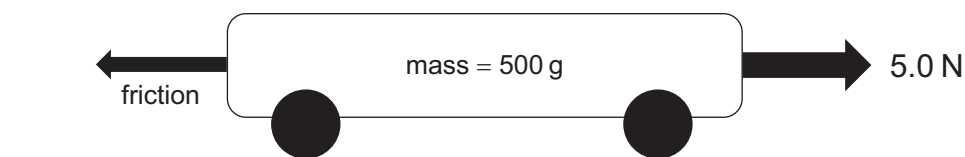

- (ii) The trolley has a mass of 500 g and experiences an acceleration of 6 m/s^2 .
Calculate the size of the friction force acting on the trolley.
**Show clearly how you get your answer, starting with the equation you
plan to use.**

Friction = _____ N [5]



(b) To investigate Hooke's law, the apparatus shown below was set up.

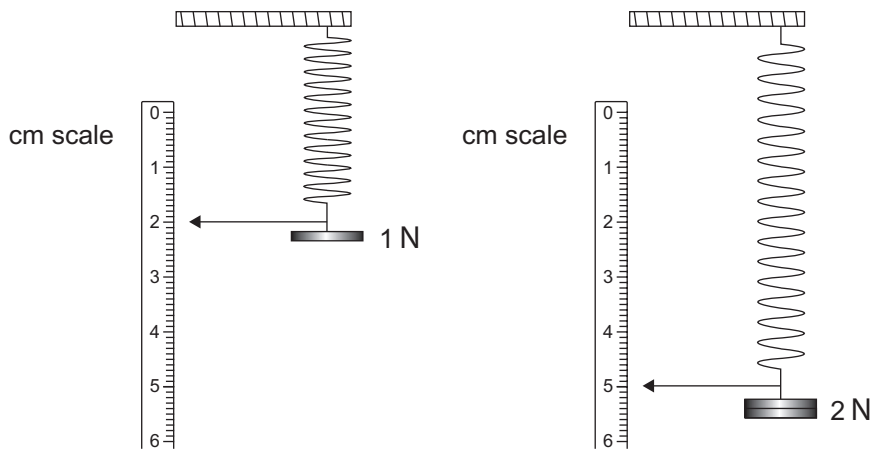

Using values from the diagrams above, calculate the value of the spring constant and state its unit.

Spring constant $k =$ _____

Unit = _____ [4]



- (c) (i) The air exerts a pressure of 10 N/cm^2 .
Explain what this means.

[2]

- (ii) A balloon has total surface area of 1200 cm^2 .

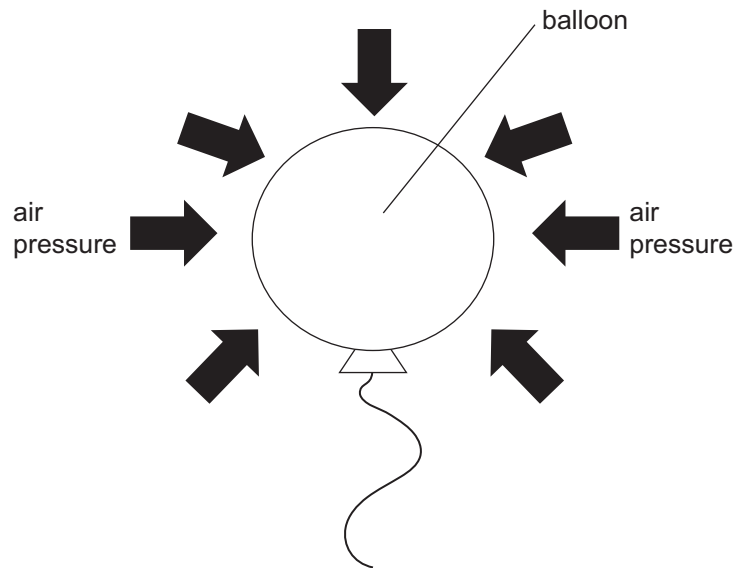

Calculate the total force acting on the balloon due to the pressure exerted by the air.

Show clearly how you get your answer, starting with the equation you plan to use.

Force = _____ N [3]



(d) Describe how the position of an object's centre of gravity and the width of its base both affect its stability.

In your answer you should:

- state the meaning of centre of gravity;
- describe how to locate the centre of gravity of a rectangular piece of wood;
- explain why an object pivoted at its centre of gravity will not turn;
- explain how the position of the centre of gravity affects the stability of an object;
- explain how the width of the base of an object affects its stability.

In this question, you will be assessed on your written communication skills including the use of specialist scientific terms.

Write your answers in the appropriate space below.

Centre of gravity _____

How to locate the centre of gravity _____

Why it does not turn _____

Centre of gravity and stability _____

Width of base and stability _____

[6]

[Turn over

14067.06R



28GPY1213

- 3 (a) The kinetic theory of matter uses the idea that all matter is composed of small particles.

Below are a number of statements about the properties of matter and the particles from which they are made.

1. Have a rigid shape.
 2. Have a fixed volume and will take up the shape of its container.
 3. Will occupy the complete volume of its container.
 4. Particles have very weak forces between them.
 5. Particles can move around.
 6. Particles are held in fixed positions.
- (i) Complete the table below by writing in the numbers of the statements which apply to each state of matter.

State of matter	Statement Numbers
Solid	
Liquid	
Gas	

[2]

- (ii) Liquid water has a density of 1.0g/cm^3 and ice has a density of 0.9g/cm^3 . Describe what happens to the volume of water as it begins to freeze.

[1]



- (b) A house owner wants to lay a concrete driveway.
The diagram below shows the finished driveway.

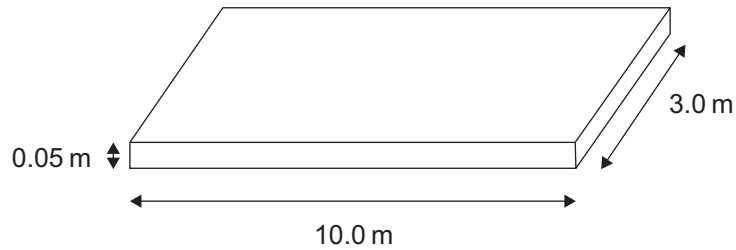

- (i) Calculate the volume of concrete needed.
Show clearly how you get your answer, starting with the equation you plan to use.

Volume = _____ m³ [2]

- (ii) Concrete has a density of 2400 kg/m³.
Calculate the mass, in tonnes, of concrete required to lay the driveway.
1 tonne = 1000 kg
Show clearly how you get your answer, starting with the equation you plan to use.

Mass = _____ tonnes [4]

[Turn over

14067.06R



28GPY1215

4 (a) Name the two methods of heat transfer that involve the movement of particles.

_____ [2]

(b) Hot objects emit heat in the form of radiation.
To investigate how the amount of radiation varies with distance **D** from the source of heat, the apparatus shown below was used. The sensor produced a reading on the detector when it detected heat.

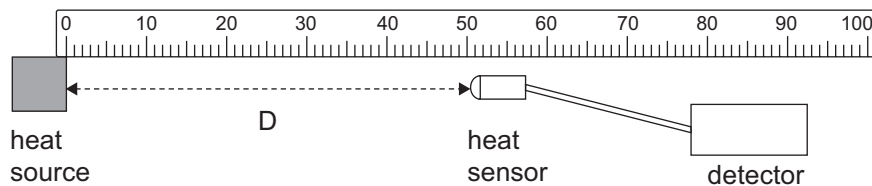

The investigation produced the values shown in the table below.

Distance D from the heat source/m	Reading R on the detector/V
0.4	68
0.6	30

The relationship between the reading R on the detector and the distance D is given by the equation below.

$$K = RD^2$$

K is a constant.

Using the values shown in the table, calculate an average value for K.
Give your average value for K to the **nearest whole number**.

Show your calculations clearly.

Average value for K = _____ Vm² [3]

[Turn over



(c) A ball is released from rest at point A and rolls down a slope.

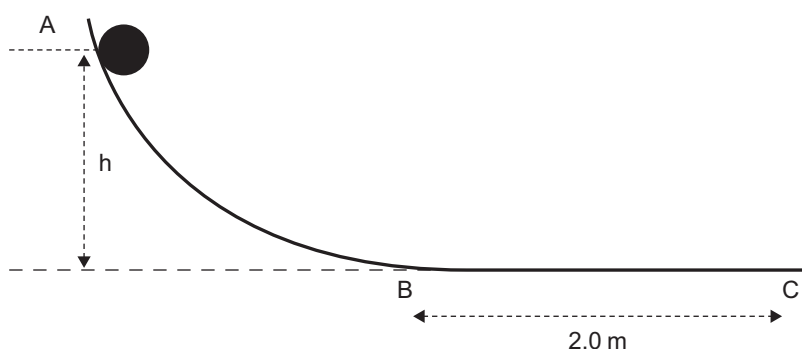

- (i) The potential energy of the ball at the point A is 3.0 J.
The ball has a mass of 200 g.
Calculate the height h .
Show clearly how you get your answer, starting with the equation you plan to use.

$$h = \text{_____} \text{ m [4]}$$

- (ii) As it rolls down the slope, the ball loses 0.5 J of energy.
Calculate its kinetic energy and velocity when it reaches point B.
Show clearly how you get your answer, starting with the equation you plan to use.

$$\text{Kinetic energy} = \text{_____} \text{ J}$$

$$\text{Velocity} = \text{_____} \text{ m/s [5]}$$



- (iii) The ball stops at C.
The distance the ball travels from B to C is 2.0 m.
Calculate the friction force acting on the ball as it travels from B to C.
Show clearly how you get your answer, starting with the equation you plan to use.

Friction = _____ N [3]

- (d) An electric motor is used to raise a load as shown below.

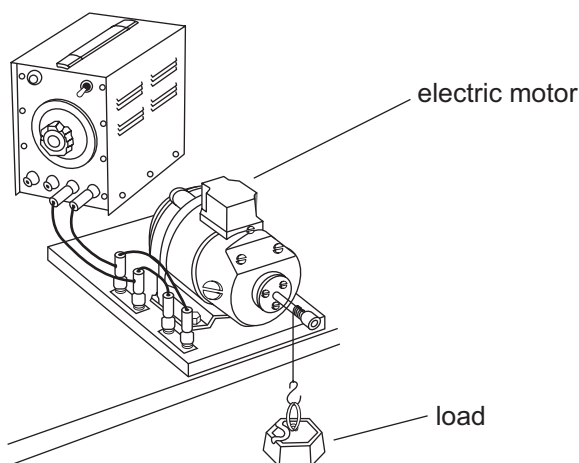

Source: Reproduced with the kind permission of the Institute of Physics

- (i) The motor uses 500 J of electrical energy and the load gains 450 J of potential energy when it reaches the top.
Calculate the efficiency of the electric motor.
Show clearly how you get your answer, starting with the equation you plan to use.

Efficiency = _____ [3]

[Turn over

14067.06R



28GPY1219

- (ii) It takes the motor 5.0 s to raise the load.
Calculate the **output** power of the motor.
Include the unit of power with your answer.
Show clearly how you get your answer, starting with the equation you plan to use.

Power = _____

Unit = _____ [4]





BLANK PAGE

DO NOT WRITE ON THIS PAGE

(Questions continue overleaf)

[Turn over

14067.06R



28GPY1221

5 (a) (i) Name one **major** source of background radiation.

_____ [1]

The count rates from a radioactive source are corrected for background radiation and the results are shown in the table below.

Time/s	0	50	100	150	200	250
Corrected count rate/ counts/minute	128	90	64	45	32	21

(ii) Use the table to determine the half-life of this radioactive source.

Half-life = _____ s [2]

(iii) Calculate the time that must elapse before the count rate falls below 8 counts/minute.

Show clearly how you get your answer.

Time = _____ s [3]



(b) An isotope of sodium (Na) is radioactive and decays to magnesium (Mg) by emitting a beta particle.

(i) Complete the decay equation below.



[5]

This isotope of sodium is often used as a means of detecting leaks from underground water pipes. The isotope is added to the water pipe and a detector is moved along the ground until an increase in the activity is detected. **The half-life of this isotope is 15 hours.**

Image removed due to copyright

Source: <https://detectaleak.com.au/wp-content/uploads/2012/06/gas-injected.jpg>

(ii) Explain why a radioactive source that emits alpha (α) particles would not be suitable for this task.

_____ [1]

(iii) Another radioactive source is available that emits beta particles. However, it has a half-life of three days. Explain why this radioactive source would not be suitable for this task.

_____ [1]

[Turn over

14067.06R



28GPY1223

(c) The International Thermonuclear Experimental Reactor (ITER) is a research and development programme based in France.

(i) Name the nuclear process that ITER is investigating.

_____ [1]

(ii) Describe in terms of nuclei what happens in this process that ITER is investigating.

_____ [2]

(iii) Where does this nuclear process occur naturally in our Solar System?

_____ [1]

THIS IS THE END OF THE QUESTION PAPER





BLANK PAGE
DO NOT WRITE ON THIS PAGE

14067.06R



28GPY1225

BLANK PAGE
DO NOT WRITE ON THIS PAGE

14067.06R



28GPY1226





BLANK PAGE

DO NOT WRITE ON THIS PAGE

14067.06R



28GPY1227

DO NOT WRITE ON THIS PAGE

For Examiner's use only	
Question Number	Marks
1	
2	
3	
4	
5	

Total Marks	
--------------------	--

Examiner Number

Permission to reproduce all copyright material has been applied for.
In some cases, efforts to contact copyright holders may have been unsuccessful and CCEA will be happy to rectify any omissions of acknowledgement in future if notified.

GPY12/7
290815



28GPY1228